

TERRI 3HT
Tracked harvester

TERRI
FOR ALL TERRAIN



TERRI 3HT

Tracked harvester

Do the conditions make a good job unlikely? Then it is time to call in the expert! Accessibility, comfort and flexibility are just three words that are synonymous with Terri 3HT.

It thrives with first and second thinning and when driving on sensitive ground. Thanks to its first-rate range, it does a perfect job even when the terrain is uncompromising.

Focus on driver comfort

Get into a Terri 3HT and experience the comfort: airy, spacious cabins that are equipped with technology and amenities adapted for long working days. Everything has been sketched and studied down to the smallest detail so it is no surprise that our cabins are often compared to larger forestry machines.

The chair is ergonomically designed, and as a driver you have a perfect overview of the working area thanks to large wrap-around wind-screens. The fully automatic climate

control system ensures comfortable air circulation and the right temperature whatever the season. The placement of the lighting has been carefully selected, meaning that you can perform qualitative felling, regardless of the time of day.

Both the driving and working experience are important to us. That is why we have equipped Terri 3HT with MOWI P40, a powerful crane that ensures a range of just over six metres. This really makes the work easier in dense and unforgiving terrain.

How do you want to equip your new machine? There are many possibilities. Depending on what you are aiming for, we manufacture your machine so that your working days are adapted entirely to your wishes. Our goal is flexible shifts with minimal impact on your body and the forest. No matter the surface or land.

Are you looking for a flexible, easily manoeuvrable harvester with optimal performance? Then look no further than a Terri 3HT!

Thanks to smart solutions, time is saved when it comes to daily maintenance and service. Among other things, you can check the oil without having to open the bonnet.

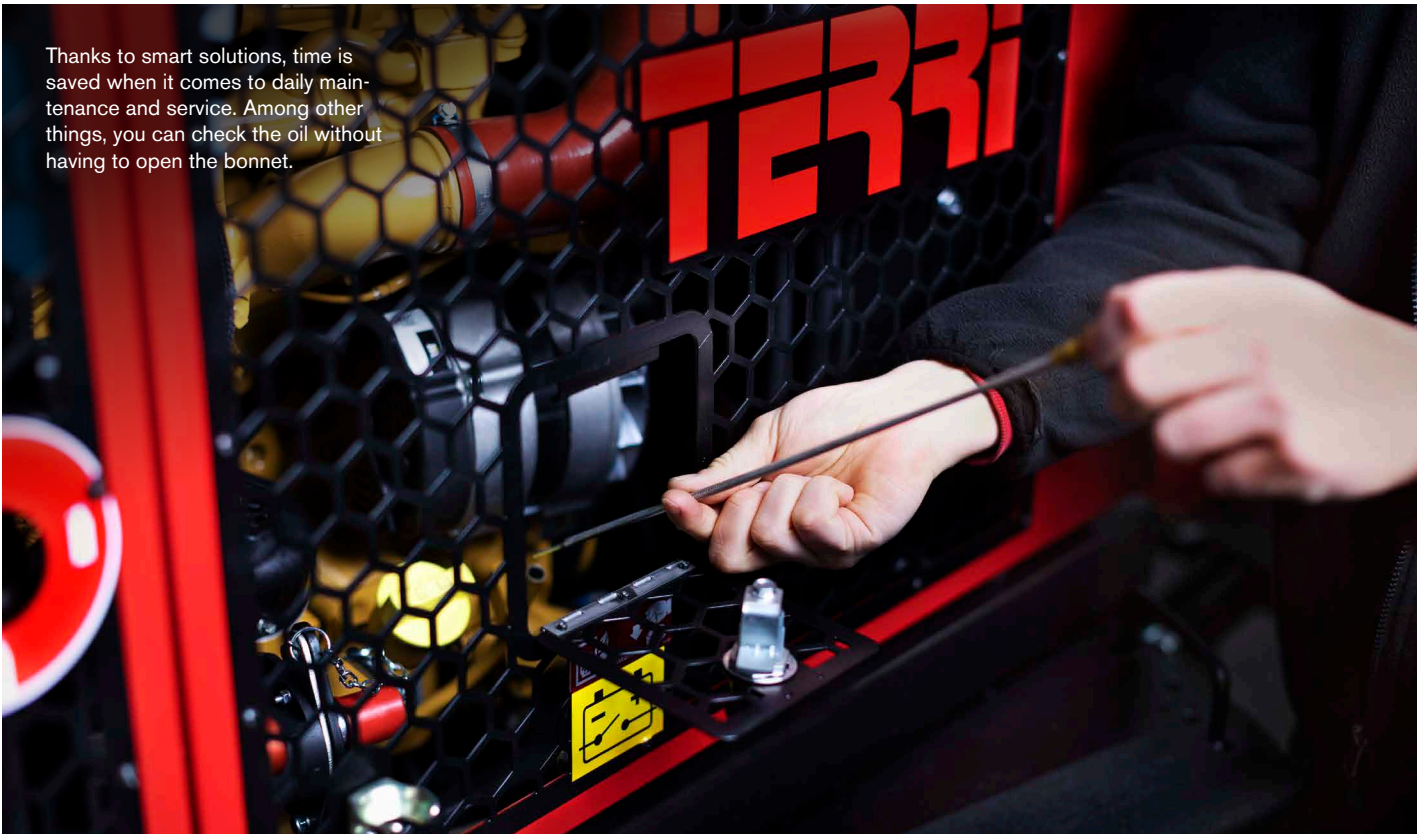

Made for accessibility

Forget about the ground and forest looking unwelcoming. Terri 3HT thrives best in the most challenging conditions. This is the harvester that is not afraid of tougher and trickier work situations. That is when the flexibility and power work best of all.

Thanks to MOWI P40, a first-class range is ensured when accessibility looks woeful.

Fully automatic optimal traction

Terri 3HT may run on tracks, but it still has the Terri AWS (Automatic Wheel System), which has replaced the old differential lock as standard.

Terri AWS gives you a fully automatic solution where the machine itself detects when the system should be active or not in order to ensure optimal traction. There are many benefits. These include a smoother and more comfortable driving experience, while fuel consumption is also reduced.

Compared with the previous

technology, this means that the power is used where it is needed the most. Both traction and power are guaranteed to generate the right amount of power to each wheel without you as a driver needing to do anything. The difference becomes noticeably clear on steep terrain or on ground with poor bearing capacity.

Terri AWS is our own invention. Something we say with pride.

Ready for all terrain

Terri 3HT is not just a strong and robust harvester. It is also easy to drive and can easily tackle terrain that many other forestry machines cannot manage.

Thanks to its low ground pressure, it is an ideal work partner even on sensitive ground or when the felling area is difficult to access.

24-volt electrical system

As one of the few manufacturers in this machine class, we manufacture Terri 3HT with a 24-volt electrical system. In addition to the machine being less sensitive to power surges, this also guarantees a more stable and secure power supply when

the electrical system requires high power. We are also throwing into the bargain the fact that it is easier to start.

That is actually not so unusual – we are just following the industry standard – but the benefits are huge.

Fuel-efficient engine

Thanks to the increased cylinder volume of 3.6 litres, we have gained higher torque, making the machine powerful even at low speeds. The result is an engine that is more fuel-efficient and powerful than its predecessors.

Smart service solutions

A number of ingenious and smart solutions save time on both daily maintenance and ongoing service. The engine compartment is extremely easy to access and you can check the engine oil without having to open the bonnet.

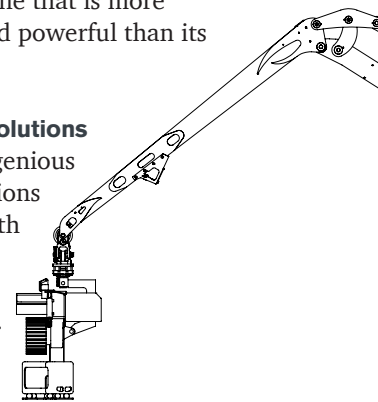

TERRI | AUTOMATIC
AWS | WHEEL
SYSTEM

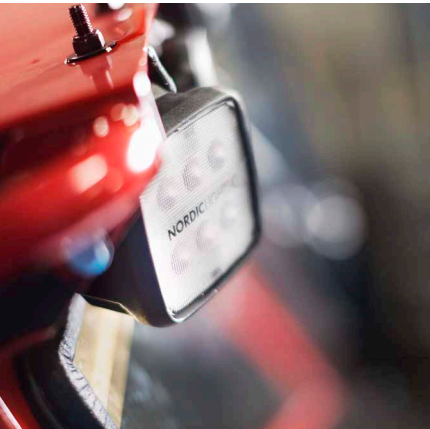

DIMENSION SKETCH

External dimensions and measurements are based on the base machine. All measurements are given in millimetres.

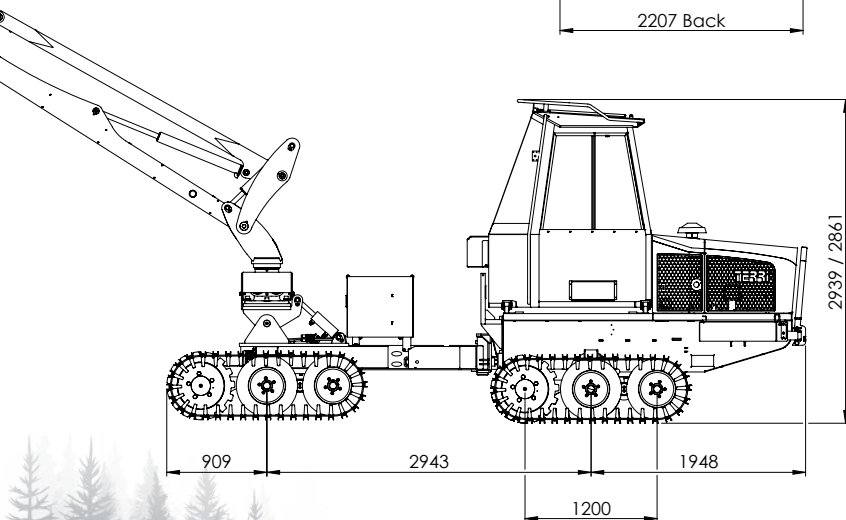
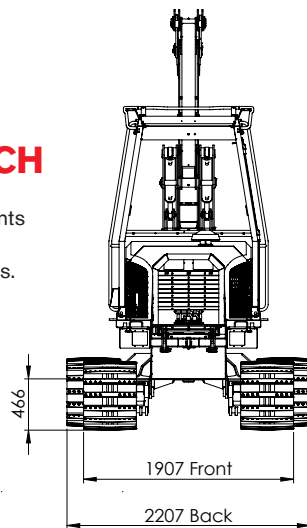

TECHNICAL DATA

| | |
|--------------------------|---------------------------------|
| Diesel engine | CAT 3.6 |
| Power | 55.4 kW |
| Number of cylinders | 4 |
| Torque | 424 Nm/1,200 rpm |
| Diesel tank volume | 100 l |
| Transmission | Fully hydraulic |
| Max. steering angle | 45° |
| Gears | 1, 2 and reverse |
| Max. speed | 11 km/h |
| Track width | 490 mm |
| Hydraulic system | Danfoss |
| Tank volume | 120 l |
| Pump capacity | 120 cc |
| Electrical system | 24 V |
| Battery | 2x12 V/100 Ah |
| Generator | 100 A |
| Crane | Mowi |
| Model | P40 |
| Lifting torque | 37 kNm |
| Slewing torque | 12 kNm |
| Slewing arc | 220° |
| Reach | 6.2 m |
| Harvester head | Log Max |
| Model | LM 2000T |
| Feed rate | 3.1/4.0 m/sec |
| Feed force | 14.9 kN |
| Number of feed wheels | 2 |
| Max. opening | 330 mm |
| Chassis | |
| Service weight | 6,600 kg |
| Length, standard | 5,700 mm |
| Width | Front 1,900 mm Back 2,200 mm |
| Highest height | 2,900 mm |
| Ground clearance | 400 mm |

Terri reserves the right to make technical changes.



SUSTAINABLE FORESTRY – OUR RESPONSIBILITY

We develop our machines based on three basic requirements: gentleness to nature, comfortable workplaces for the driver and, of course, the right properties for efficient and smart forestry work.

As a manufacturer of modern forestry machines, we play a decisive role

that includes great responsibility for the future and sustainable forestry.

Thanks to their low ground pressure, our constructions also enable minimal impact on the environment, regardless of terrain.

With Terri 3HT, we have made a

machine that allows both the driver and the environment to thrive. Our goal is for you in your future work to have a harvester that really does the job in the absolute best way possible. Shift after shift. That is the cornerstone of our manufacturing.

Welcome to the Terri family!



YOUR MACHINE – YOUR WISHES

When buying a Terri, you have many options for putting your own stamp on the machine. Among these, you will find a multitude of smart options that you can have fitted and installed. Read more in our catalogue at terri.se or contact our sellers for more information.

Terri develops and manufactures powerful machines for professional and sustainable forestry that are specially adapted for stand-operative thinning. The model programme is characterised by compact machines with low ground pressure for gentle and efficient work.

Terri is a brand under Alfing i Älmhult AB, which in turn is part of the Inev Group with sales of SEK 1.3 billion. The machines are built in Älmhult, in the Swedish region of Småland with the forest right on its doorstep.

The group has its own development, design and manufacture of hydraulic cylinders and cabins, among other things. Extensive knowledge and many years of experience within the Inev Group provide a solid foundation for its ongoing development work.