

TERRI 3FW
Wheeled forwarder

TERRI
FOR ALL TERRAIN



TERRI 3FW

Wheeled forwarder

Rocky, steep or sensitive terrain. With a Terri 3FW, you will do a top job every time – on ground that few other machines can manage.

High ground clearance, easy manoeuvrability and cabin comfort that your body will rejoice in make our forwarder one of the best machines in its class. Thrown into the bargain, you get a robust workhorse that is not afraid of anything.

Focus on driver comfort

We place great emphasis on an optimal work environment in all of our machines. In many ways our cabins are top of the class and can be compared with large forestry machines: airy, spacious and equipped with technology and amenities that make the working days both enjoyable and smooth. Everything has been sketched and studied down to the smallest detail and adapted for long shifts. The fully automatic climate control system ensures

comfortable air circulation and the right temperature. The chair is ergonomically designed, and as the driver you have a perfect overview of the working area thanks to the machine's large wrap-around wind-screens. The intelligently located lighting means that you can carry out the same quality forwarding regardless of the time of day.

Thanks to the 70-centimetre ground clearance the negotiability in the forest is fantastic. Eight wheels ensure a high degree of ground

contact, which is optimal for traction and driver comfort. All wheels are drive wheels, which provides major benefits in terrain that is hilly or has low bearing capacity. What is more, the driving experience is less bumpy and rough as the cabin rests on pairs of double wheels.

And of course you can fit tracks as well as chains to pairs of wheels.

Terri 3FW makes forwarding a pure joy. No matter the terrain.



Under the bonnet is a powerful and fuel-efficient 3.6-litre engine. Also new is the fact that all of our machines are now manufactured with a 24-volt electrical system for a more stable and secure power supply.

Fully automatic optimal traction

Terri Automatic Wheel System (AWS) has replaced the old differential lock as standard. This gives you a fully automatic solution where the machine itself detects when the system should be active or not in order to ensure optimal traction. There are many benefits. Driving is smoother and more comfortable, while fuel consumption is also reduced.

We are proud to say that Terri AWS is our own innovation. Compared with previous technology, this means that the power is used where it is needed the most. Both traction and power are guaranteed to generate more and the right amount of power to each wheel without you as a driver needing to do anything. The difference becomes noticeably clear on steep terrain or on ground with poor bearing capacity.

Manages all kinds of terrain

Terri 3FW is not just a strong and robust forwarder. It is also easy to drive and can easily tackle terrain

that many other forestry machines cannot manage.

It does this thanks to its low ground pressure, making it an ideal partner, even on sensitive ground.

Fantastic ground clearance

Did you know that the ground clearance is at the same level as in the largest forestry machine models? Everyday work is made considerably easier thanks to the 70-centimetre clearance. You can now venture without a second thought into tougher terrain without it affecting your work.

24-volt electrical system

As one of the few manufacturers in this machine class, we have designed Terri 3FW with a 24-volt electrical system. When the machine is in operation and the electrical system requires high power, you get a more stable and secure power supply with 24 volts. It is also less sensitive to power surges. We are also throwing into the bargain the fact that it is significantly easier to start.

That is actually not so unusual – we are just following the industry standard – but the benefits are huge.

Smart service solutions

Thanks to a number of smart solutions, time is saved on daily maintenance and ongoing service. The engine compartment is extremely easy to access, and if you need to check the engine oil, you can do so without having to open the bonnet.

Fuel-efficient engine

With an increased cylinder volume of 3.6 litres, we have gained higher torque, making the machine powerful even at low speeds. The result? An engine that is more fuel-efficient and powerful than its predecessors.

The engine is designed based on the conditions and requirements that pertain to a forestry machine.

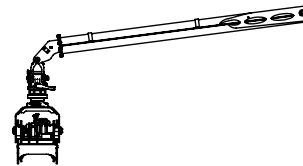

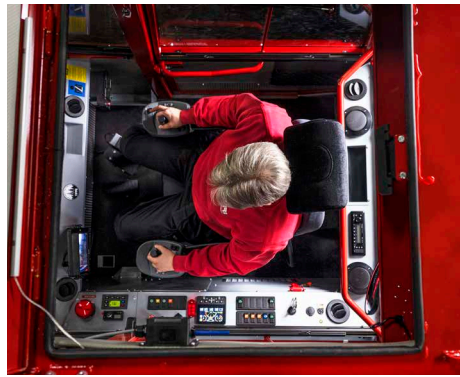

DIMENSION SKETCH

External dimensions and measurements are based on the base machine. All measurements are given in millimetres.

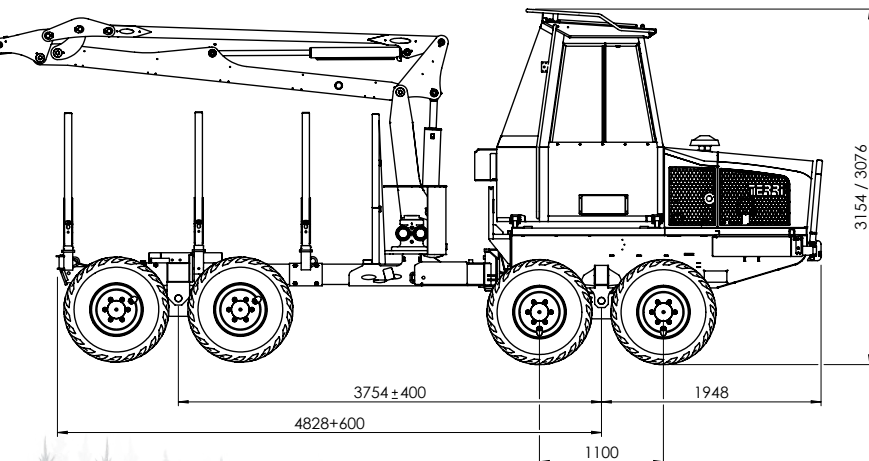
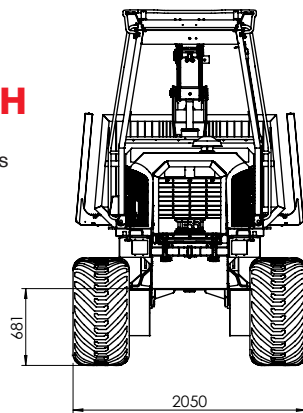

TECHNICAL DATA

Diesel engine	CAT 3.6
Power	55.4 kW
Number of cylinders	4
Torque	424 Nm/1,200 rpm
Diesel tank volume	100 l
Transmission	Fully hydraulic
Max. steering angle	45°
Gears	1, 2, 3 and reverse
Max. speed	18 km/h
Wheel dimension	500/50 x 17
Hydraulic system	Danfoss
Tank volume	120 l
Pump capacity	130 cc
Electrical system	24 V
Battery	2x12 V/100 Ah
Generator	100 A
Crane	Mowi
Model	P30/P30T/P40/P40T
Lifting torque	31 kNm/37 kNm
Slewing torque	8.5 kNm/12 kNm
Slewing arc	360°
Reach	5.7/6.7/6.2/7.5 m
Chassis	
Service weight	6,100 kg
Length, standard	6,600–7,200 mm
Length, extra long	7,200–7,800 mm
Width	2,050 mm
Highest height	3,100/3,180 mm
Ground clearance	700 mm
Loading area	2–2.45 m ²

Terri reserves the right to make technical changes.



WE FOCUS ON SUSTAINABLE FORESTRY

As a manufacturer of modern forestry machines, we play a decisive role that includes great responsibility for the future and sustainable forestry.

That is why we develop our machines based on three basic requirements: gentleness to nature, comfortable workplaces for the driver and, of course, the right properties for

efficient and smart forestry work. Thanks to its low ground pressure, Terri 3FW causes minimal ground damage. The machine weight with a full load is distributed over eight wheels, and, if you want to strengthen the traction and reduce the ground pressure further, the machine can be supplemented with belts or chains.

If you choose a Terri 3FW as your future workplace, you will get a forwarder that you can really rely on. The work is performed efficiently and rationally, and always with a great respect for the forest, land and nature.

Welcome to the Terri family!



YOUR MACHINE - YOUR WISHES

When buying a Terri, you have many options for putting your own stamp on the machine. Among these, you will find a multitude of smart options that you can have fitted and installed. Read more in our catalogue at terri.se or contact our sellers for more information.

Terri develops and manufactures powerful machines for professional and sustainable forestry that are specially adapted for stand-operative thinning. The model programme is characterised by compact machines with low ground pressure for gentle and efficient work.

Terri is a brand under Alfing i Älmhult AB, which in turn is part of the Inev Group with sales of SEK 1.3 billion. The machines are built in Älmhult, in the Swedish region of Småland with the forest right on its doorstep.

The group has its own development, design and manufacture of hydraulic cylinders and cabins, among other things. Extensive knowledge and many years of experience within the Inev Group provide a solid foundation for its ongoing development work.